

## CLIENT

**Macquarie Bank**

## CONSULTANT

**M E Engineers Ltd**

## PRODUCT

**MUBP - Clip In**

## ELECTRICAL CONTRACTOR

**Unidata**

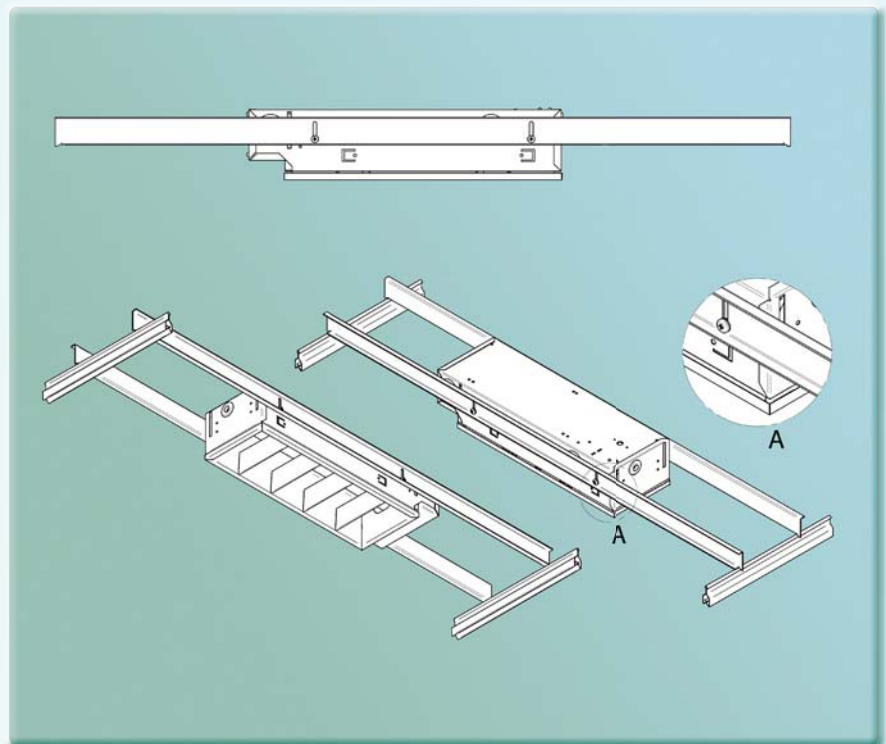
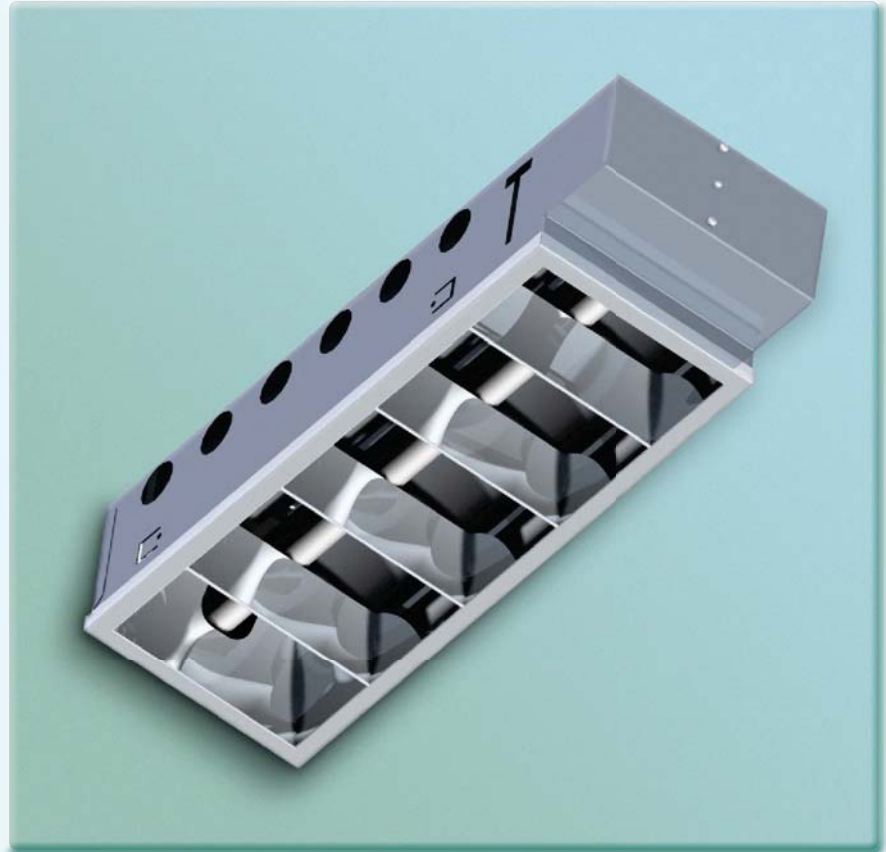

Existing ceiling tiles with cutouts meant finding a manufacturer who had a flexible product range as the original supplier no longer existed.

Because of our flexible manufacturing and wide range of tooling, we were able to supply fittings from initial enquiry to delivery in 4 weeks. Special linear brackets spanned the SAS 150 ceiling.